

# VERSATILE ADAPTER

## OWNER'S MANUAL

PLEASE READ MANUAL  
COMPLETELY BEFORE  
OPERATION

### INTRODUCTION:

**WELCOME TO THE VERSATILE ADAPTER!** You have purchased the most convenient accessory introduced to the R/C modeler in years. If you are tired of the "rats nest" of spliced (and expensive) Y-hook-ups to let you connect chargers, battery cyclers, test equipment, servo cyclers, etc. to your batteries and equipment, **VERSATILE ADAPTER** is the answer. The **VERSATILE ADAPTER** offers over 80 combinations of connections that, if you purchased adapter cables, would cost over \$400! If one chooses to use any one of the standard connectors provided as a "master" equipped with alligator clips, the connections that can be made are endless.

### SPECIFICATIONS:

<b>CONNECTORS PROVIDED:</b>	MOLEX (HITEC), DEANS 3-PIN MALE, FUTABA J TYPE, JR, AIRTRONICS (REVERSE POLARITY OF OTHERS)
<b>INTERCONNECTIONS:</b>	POSITIVE TERMINALS ARE ALL INTERCONNECTED
<b>VOLTAGE COMPATIBILITY:</b>	VERSATILE ADAPTER IS INTENDED FOR USE WITH DC
<b>CURRENT CAPACITY:</b>	VERSATILE ADAPTER INTERCONNECTIONS CAN HANDLE

### APPLICATION:

The uses for **VERSATILE ADAPTER** are limited only by one's imagination. Use **VERSATILE ADAPTER** to interface between battery chargers and cyclers; interface your receiver with different servo types for bench tests; etc.

**CAUTION:** Please note the polarity on your batteries and chargers when hooking them up to **VERSATILE ADAPTER**. Never attempt to mix Airtronics with other R/C brand connectors. Both barrel jacks on **VERSATILE ADAPTER** are wired with "tip plus" and "sleeve ground". Certain model JR R/C transmitters are the reverse of this!!!!

FMA Direct  
5716A Industry Lane  
Frederick, MD 21704  
PHONE: (301) 668-7614

**FMA**  
Direct

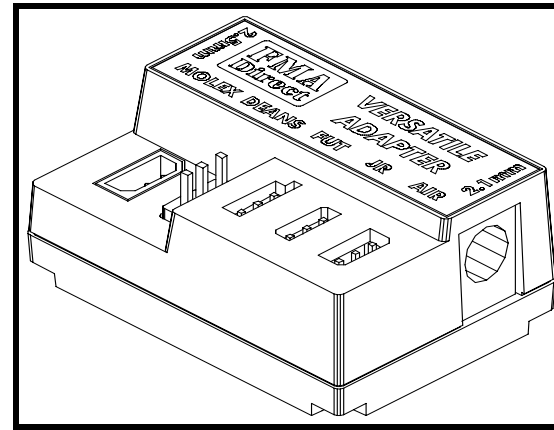

# VERSATILE ADAPTER

## OWNER'S MANUAL

PLEASE READ MANUAL  
COMPLETELY BEFORE  
OPERATION

### INTRODUCTION:

**WELCOME TO THE VERSATILE ADAPTER!** You have purchased the most convenient accessory introduced to the R/C modeler in years. If you are tired of the "rats nest" of spliced (and expensive) Y-hook-ups to let you connect chargers, battery cyclers, test equipment, servo cyclers, etc. to your batteries and equipment, **VERSATILE ADAPTER** is the answer. The **VERSATILE ADAPTER** offers over 80 combinations of connections that, if you purchased adapter cables, would cost over \$400! If one chooses to use any one of the standard connectors provided as a "master" equipped with alligator clips, the connections that can be made are endless.

### SPECIFICATIONS:

<b>CONNECTORS PROVIDED:</b>	MOLEX (HITEC), DEANS 3-PIN MALE, FUTABA J TYPE, JR, AIRTRONICS (REVERSE POLARITY OF OTHERS)
<b>INTERCONNECTIONS:</b>	POSITIVE TERMINALS ARE ALL INTERCONNECTED
<b>VOLTAGE COMPATIBILITY:</b>	VERSATILE ADAPTER IS INTENDED FOR USE WITH DC
<b>CURRENT CAPACITY:</b>	VERSATILE ADAPTER INTERCONNECTIONS CAN HANDLE

### APPLICATION:

The uses for **VERSATILE ADAPTER** are limited only by one's imagination. Use **VERSATILE ADAPTER** to interface between battery chargers and cyclers; interface your receiver with different servo types for bench tests; etc.

**CAUTION:** Please note the polarity on your batteries and chargers when hooking them up to **VERSATILE ADAPTER**. Never attempt to mix Airtronics with other R/C brand connectors. Both barrel jacks on **VERSATILE ADAPTER** are wired with "tip plus" and "sleeve ground". Certain model JR R/C transmitters are the reverse of this!!!!

FMA Direct  
5716A Industry Lane  
Frederick, MD 21704  
PHONE: (301) 668-7614

**FMA**  
Direct

## ACCESSORIES

A multitude of 2.5mm and 2.1mm barrel plug cables and numerous other accessories as well as a full line of servos is available for use with your FMA VERSATILE ADAPTER from your local FMA dealer.

### FMA LIMITED WARRANTY ON VERSATILE ADAPTER

#### LENGTH OF WARRANTY

This warranty begins on the date of original purchase. All FMA, Inc. VERSATILE ADAPTERS carry a limited one year warranty against defects in material and workmanship.

#### WHO MAY ENFORCE THE WARRANTY

This warranty may be enforced only by the original purchaser.

#### WHAT IS COVERED AND WHAT IS NOT COVERED

Except as specified below, this warranty covers all defects in material and workmanship in this product. The following are not covered by the warranty:

1. Damage resulting from accident, misuse, abuse, neglect, electrical surges, reversed polarity on connectors, lightning or other acts of God.
2. Damage from failure to follow instructions supplied with the product.
3. Damage occurring during shipment of the product either to the customer or from the customer for service (claims must be presented to the carrier).
4. Damage resulting from repair, adjustment, or any alteration to product by any one other than an authorized FMA technician.

#### WHAT WE WILL PAY FOR

We will pay all labor and material expenses for items covered by the warranty. Payment of shipping charges is discussed in the next section of this warranty.

#### HOW YOU CAN GET WARRANTY SERVICE

Your unit must be serviced by an authorized FMA service station. If you have experienced a problem with your FMA product that you feel should be covered by warranty, contact FMA, Inc. immediately and obtain information on where to send your defective product for service. You must pay any shipping charges to the service center. The return postage will be paid by FMA, Inc. provided the repair is covered under warranty, and the shipping destination is within the United States. Always include a brief description of the problem, **a copy of your original sales receipt**, your name, address, and telephone number in the event we have a problem.

#### EXCLUSION OF DAMAGES

FMA's liability for any defective product is limited to repair or replacement of the product, at FMA's option. FMA SHALL NOT BE LIABLE FOR:

1. DAMAGES BASED UPON INCONVENIENCE, LOSS OF USE OF THE PRODUCT, OR COMMERCIAL LOSS; OR
2. ANY OTHER DAMAGES, WHETHER INCIDENTAL, CONSEQUENTIAL OR OTHERWISE.

#### FMA, INCORPORATED

5716A Industry Lane  
Frederick, MD 21704  
PHONE: (301) 831-8980

## ACCESSORIES

A multitude of 2.5mm and 2.1mm barrel plug cables and numerous other accessories as well as a full line of servos is available for use with your FMA VERSATILE ADAPTER from your local FMA dealer.

### FMA LIMITED WARRANTY ON VERSATILE ADAPTER

#### LENGTH OF WARRANTY

This warranty begins on the date of original purchase. All FMA, Inc. VERSATILE ADAPTERS carry a limited one year warranty against defects in material and workmanship.

#### WHO MAY ENFORCE THE WARRANTY

This warranty may be enforced only by the original purchaser.

#### WHAT IS COVERED AND WHAT IS NOT COVERED

Except as specified below, this warranty covers all defects in material and workmanship in this product. The following are not covered by the warranty:

1. Damage resulting from accident, misuse, abuse, neglect, electrical surges, reversed polarity on connectors, lightning or other acts of God.
2. Damage from failure to follow instructions supplied with the product.
3. Damage occurring during shipment of the product either to the customer or from the customer for service (claims must be presented to the carrier).
4. Damage resulting from repair, adjustment, or any alteration to product by any one other than an authorized FMA technician.

#### WHAT WE WILL PAY FOR

We will pay all labor and material expenses for items covered by the warranty. Payment of shipping charges is discussed in the next section of this warranty.

#### HOW YOU CAN GET WARRANTY SERVICE

Your unit must be serviced by an authorized FMA service station. If you have experienced a problem with your FMA product that you feel should be covered by warranty, contact FMA, Inc. immediately and obtain information on where to send your defective product for service. You must pay any shipping charges to the service center. The return postage will be paid by FMA, Inc. provided the repair is covered under warranty, and the shipping destination is within the United States. Always include a brief description of the problem, **a copy of your original sales receipt**, your name, address, and telephone number in the event we have a problem.

#### EXCLUSION OF DAMAGES

FMA's liability for any defective product is limited to repair or replacement of the product, at FMA's option. FMA SHALL NOT BE LIABLE FOR:

1. DAMAGES BASED UPON INCONVENIENCE, LOSS OF USE OF THE PRODUCT, OR COMMERCIAL LOSS; OR
2. ANY OTHER DAMAGES, WHETHER INCIDENTAL, CONSEQUENTIAL OR OTHERWISE.

#### FMA, INCORPORATED

5716A Industry Lane  
Frederick, MD 21704  
PHONE: (301) 831-8980